



**DISTRIBUTED BY**  
**JB Prince Company, Inc.**  
 ADDRESS 36 East, 31st Street, 11th Floor, New York, NY 10016  
 LOCAL (212) 683 - 3553  
 TOLL FREE (800) 473 - 0577  
 FAX (212) 683 - 4488  
 EMAIL customerservice@jbprince.com  
 WEBSITE jbprince.com

VACUUM PACKING MACHINE LYNX 42 - SPEC SHEET

**LYNX 42**  
**VACUUM PACKAGING MACHINE**



**DESCRIPTION**  
 The state-of-the-art Lynx 42 vacuum packer is standard equipped with a Busch vacuum pump, Advanced Control System which is label printer compatible, Sensor control that ensures an optimum vacuum every cycle, and special marinating and packaging functions. This model is ETL listed and complies with UL, CSA and CE standards.

- FEATURES**
- Seal bar length: 16.5"
  - Seal bar with two wires, for double security
  - Seal bar easily removable for cleaning and maintenance purposes
  - Easy to clean flat chamber
  - Pump capacity: 678 cf/h (19 m<sup>3</sup>/h) Busch vacuum pump
  - Pump maintenance and cleaning program
  - Machine cycle: 15-30 sec
  - Advanced Control System
  - Sensor control: 1-99.8%, for an optimum and consistent vacuum and cycle time
  - Soft Air to protect the product and vacuum pouch
  - 20 program memory
  - Transparent lid, which opens automatically after every cycle
  - Comes with insert plates for a faster cycle and product adjustment
  - Stainless steel exterior
  - 6ft cord with Nema 5-15P plug

- OPTIONS AND ACCESSORIES**
- Cut-off seal
  - Wide seal
  - Inclined insert plate
  - Food container adaptor
  - Cart with castors and shelves
  - Liquid Control



**WARRANTY**  
 All models shown come with Henkelman's standard three year warranty against defects in materials and workmanship. For full warranty details, please refer to [www.henkelman.com](http://www.henkelman.com).

**DATE**

**APPROVAL**

**ORIGINAL HENKELMAN VACUUM SYSTEMS**  
**FIT FOR FOOD SERVICE**  
[WWW.HENKELMAN.COM](http://WWW.HENKELMAN.COM)

**HENKELMAN INC.**  
 493 W Fullerton Ave  
 Elmhurst IL, 60126

**Sales and technical support**  
 P +1 331 979 2013  
 F +1 630 359 3875  
 E [info@henkelmanusa.com](mailto:info@henkelmanusa.com)

**Service and warranty**  
 P +1 844 208 5685

# VACUUM PACKING MACHINE LYNX 42 – SPECS

VACUUM PACKING MACHINE LYNX 42 – SPEC SHEET

## DIMENSIONS

In inches

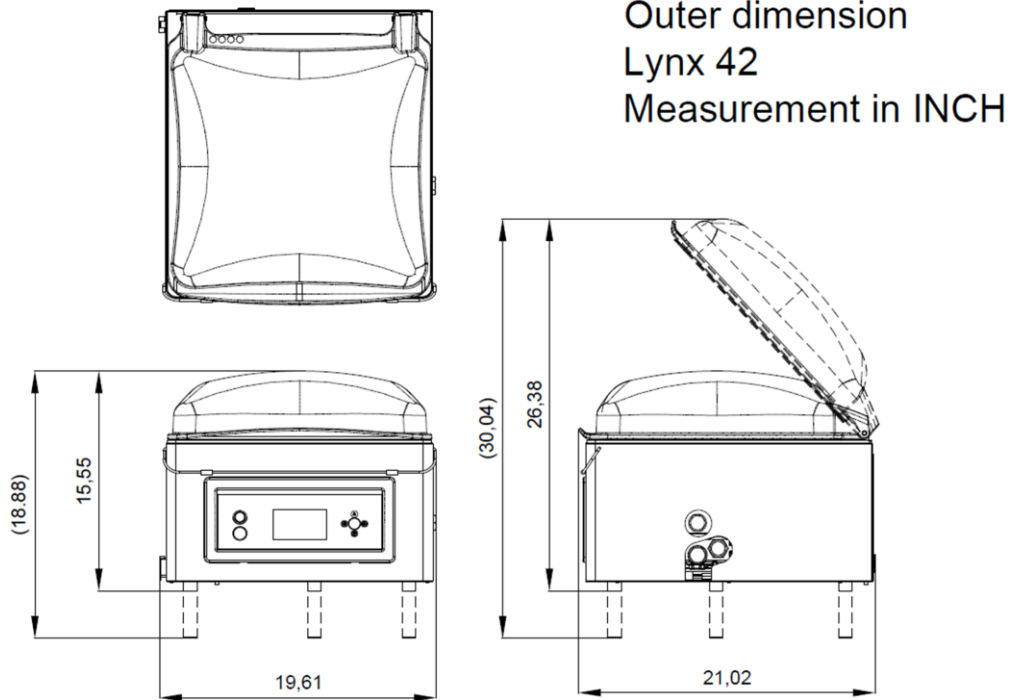

Model	Dimensions (inches)		Volts	Amps	Hz	Pump capacity	HP	Plug	Weight (lbs)
	Chamber (usable space) LxWxH	Machine LxWxH							
Lynx 42	14.2"x16.5"x4.9"	21"x19.6"x15.6"	110-120V	9	60Hz	678 cf/h (19 m <sup>3</sup> /h)	0.67	NEMA 5-15P	121

NEMA 5-15P



15 A/125 V



FIT FOR FOOD SERVICE  
[WWW.HENKELMAN.COM](http://WWW.HENKELMAN.COM)

HENKELMAN INC.  
493 W Fullerton Ave  
Elmhurst IL, 60126

Sales and technical support  
P +1 331 979 2013  
F +1 630 359 3875  
E [info@henkelmanusa.com](mailto:info@henkelmanusa.com)  
Service and warranty  
P +1 844 208 5685