

PROJECT	QUANTITY	ITEM NO
---------	----------	---------

# Heated holding cabinet

MODEL **HC-5** half-size



HC-5 Heated Holding Cabinet shown with Count Down Timer (CDT) controls. Holds 5 full-size sheet pans.

## General Information

Henny Penny heated holding cabinets are designed to hold a wide range of cooked foods at safe temperatures for long periods of time prior to serving.

These holding cabinets were originally developed to hold large quantities of pressure-fried chicken for long periods of time without sacrificing freshness or presentation. Dual fans, ventilated side racks allow hot, moist air to circulate evenly throughout the cabinet and keep practically any menu item hot and tasty until serving. And that translates into higher food quality and less waste throughout the day.

Henny Penny holding cabinets also improve your equipment and labor utilization. With longer holding periods, operators can cook in quantity before peak periods and stock heated display cases directly from the holding cabinet.

The HC-5 is a half-size mobile heated holding cabinet designed to provide excellent holding for lower volume and cost. With fully insulated door, sidewalls and control module, this holding cabinet will also lower your energy bill.

The HC-5 can be equipped with electro-mechanical controls or Count Down Timer (CDT) module. Count down timers let you program individual holding times for different items. Large time-remaining display and sound alert signal lets employees monitor holding while accomplishing other tasks.

## Standard Features

- Durable, high-quality stainless steel construction, interior and exterior.
- Count down timer module features 5 independent programmable timers with:
  - Single switch start/stop/abort, manual override and power-out memory.
  - Constant digital temperature display.
  - Separate operating time and temperature set points.
  - Sound alert signal.
  - Temperature probe calibration.
- Electro-mechanical controls feature thermostatic control, dial thermometer, on/off and cycle temperature lights.
- Removable air ducts for easy cleaning.
- Dual heavy-duty blower motors.
- Ventilating side racks.
- Partial pan removal for convenient loading and unloading.
- Fully insulated door, sidewalls and control module.
- Full perimeter door gasket.
- Self-closing, lift-off doors stay open past 90 degrees.
- Magnetic door latch and heavy-duty plated hinges.
- Standard 127 mm (5 in.) casters, two locking.

## Options

- Large stainless steel water pan.

## Please specify desired configuration

### Controls

- 5 CDT  Electro-mechanical

### Door hinge

- Right OR  Left

### Style

- Pass-through OR  Solid back

### Doors

- Stainless steel OR
- Double-pane glass

<input type="checkbox"/> APPROVED	<input type="checkbox"/> APPROVED AS NOTED	<input type="checkbox"/> RESUBMIT
AUTHORIZED SIGNATURE		DATE

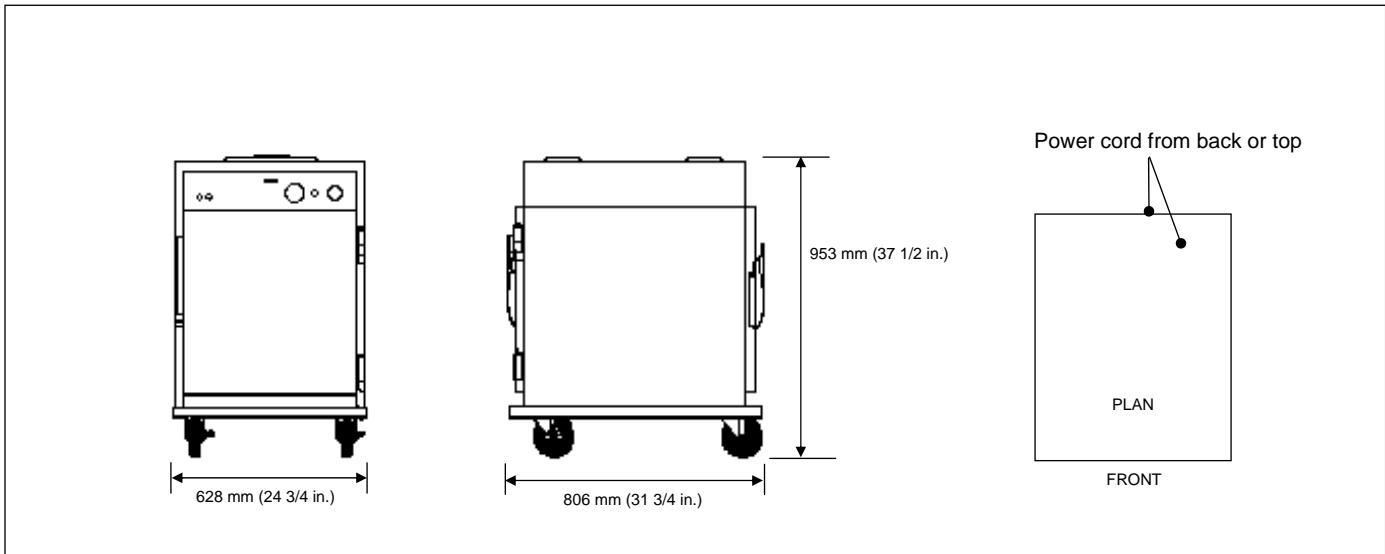

# Heated holding cabinet

MODEL **HC-5** half-size

## Dimensions

Height: 953 mm (37 1/2 in.)  
 Width: 628 mm (24 3/4 in.)  
 Depth: 806 mm (31 3/4 in.)

Required clearances: N/A

## Crated dimensions

Length: 1000 mm (39 1/2 in.)  
 Depth: 900 mm (35 1/2 in.)  
 Height: 790 mm (31 in.)  
 Volume: 0.71 m<sup>3</sup> (25 cu. ft.)

## Crated weight

HC-5 Half-size: 93 kg (206 lbs.)

Water connections: N/A

## Heating

Temperature range: 71-99°C (160-210°F)

Humidity: 3.8 liter (1 gal) water pan, optional

## Pan capacity

Accepts standard sheet pans (457 x 660 mm 18 x 26 in.).  
 HC-5 Half-size: 5 shelf runners

## Electrical

Control	Volts	Phase	Cycle/Hz	Watts	Amps	Wire
CDT	240	1	50-60	1586	6.6	2+G
EM	240	1	50-60	1612	6.7	2+G

## Bidding Specifications

- Provide Henny Penny Model HC-5 half-size Heated Holding Cabinet. Units are designed to hold hot foods in quality condition at safe temperatures for long periods of time.
- Provide choice of 5 countdown timer control module or electro-mechanical controls.
- Provide choice of right or left-hand door, solid back or pass-through design, stainless steel or double-paned glass door
- Unit shall be of stainless steel construction throughout.
- Unit shall have full perimeter door gasket and fully insulated sidewalls and control module.
- Unit shall have two heavy-duty blower motors and ventilated side racks.
- Unit shall be equipped with 4 casters 127 mm (5 in.) 2 are locking.

Continuing product improvement may subject specifications to change without notice.

Henny Penny Corporation  
 PO Box 60 Eaton OH 45320 USA  
 +1 937 456.8400 800 417.8417  
 +1 937 456.8434 Fax 800 417.8434 Fax  
[www.hennypenny.com](http://www.hennypenny.com)

**HENNY PENNY**

This product manufactured in Suzhou, China