

Infusion Coffee Brewer



ICB with 3.8L Baseless ThermoFresh® Server

(TF server and airpot sold separately)

Dimensions: 26.01"H x 10.19"W x 22.42"D
(66.1cm H x 25.9cm W x 57cm D)

Features

Infusion Coffee Brewer

- Large 3-gallon (11.36 litre) tank provides back-to-back brewing capacity
- Three brew buttons allow for 3 separate brewing profiles. Two programmable batch switches allow full and half batch brewing.
- Brews into 2.5 to 3.8 litre airpots and 3.8 and 5.7 litre baseless ThermoFresh® servers for easy transport of coffee to other locations.
- BrewWISE® intelligence with pre-infusion, pulse brew and by-pass for maximum flavor extraction. DBC grinders capable of communicating with brewer through Smart Funnel®.
- Energy-saver mode reduces tank temperature during idle periods.
- Digital display in English/Spanish for easier programming and control. Advertising messages and machine status also displayed. Display capable of showing English or Metric measurements.
- Programmable water filter change alert.
- Brew capacity varies by model. See back for details.

For current specification sheets and other information, go to www.bunn.com.

International models may vary in appearance.

Related Products

Easy Clear® EQHP-10
Product No. : 39000.0004



Easy Clear® EQHP-10L
Product No. : 39000.0001

Single/Dual Filter Pack
Product No. : 20138.0000



3.8 litre Lever-Action Airpot
Product No. : 36725.0000 (1 pack)
Product No. : 36725.0100 (6 pack)

3.0 litre Lever-Action Airpot
Product No.: 32130.0000 (1 pack)
Product No.: 32130.0100 (6 pack)

2.5 litre Lever-Action Airpot
Product No.: 32125.0000 (1 pack)
Product No.: 32125.0100 (6 pack)

Universal Airpot Racks
see spec sheet A3.9



3.8 litre (1 gal) ThermoFresh Server
Product No.: 36720.0004 (SST without base)
Product No.: 36720.0005 (BLK without base)

5.7 litre (1.5 gal) ThermoFresh Server
Product No.: 34850.0004 (SST without base)
Product No.: 34850.0005 (BLK without base)



TF Server Stand
Product No.: 38025.0000

Dimensions & Specifications

Model	Product #	Volts	Amps	Tank Heater Watts	Total Watts	Capacity	Shipping Weight	Cord Attached	Agency
ICBA	36600.0001	230	12	3000	2850	9.8 gal (37.10 L)	47.5 lbs (21.5 kg)	No	CE
ICBB	36600.0002	200	18	3400	3600		47.5 lbs (21.5 kg)	No	
Power cord	27728.0001								

Brewing capacity: based upon incoming water temp of 60°F (15.5°C) 140°F (60°C) rise.

Electrical: 230V model requires 2-wire grounded service rated 220-240V, single phase, 50/60 Hz.

200V model requires 2-wire grounded service, single phase, 50 Hz.

Plumbing: 20-90 psi (138-621 kPa). Supplied with 3/8" male flare fitting.

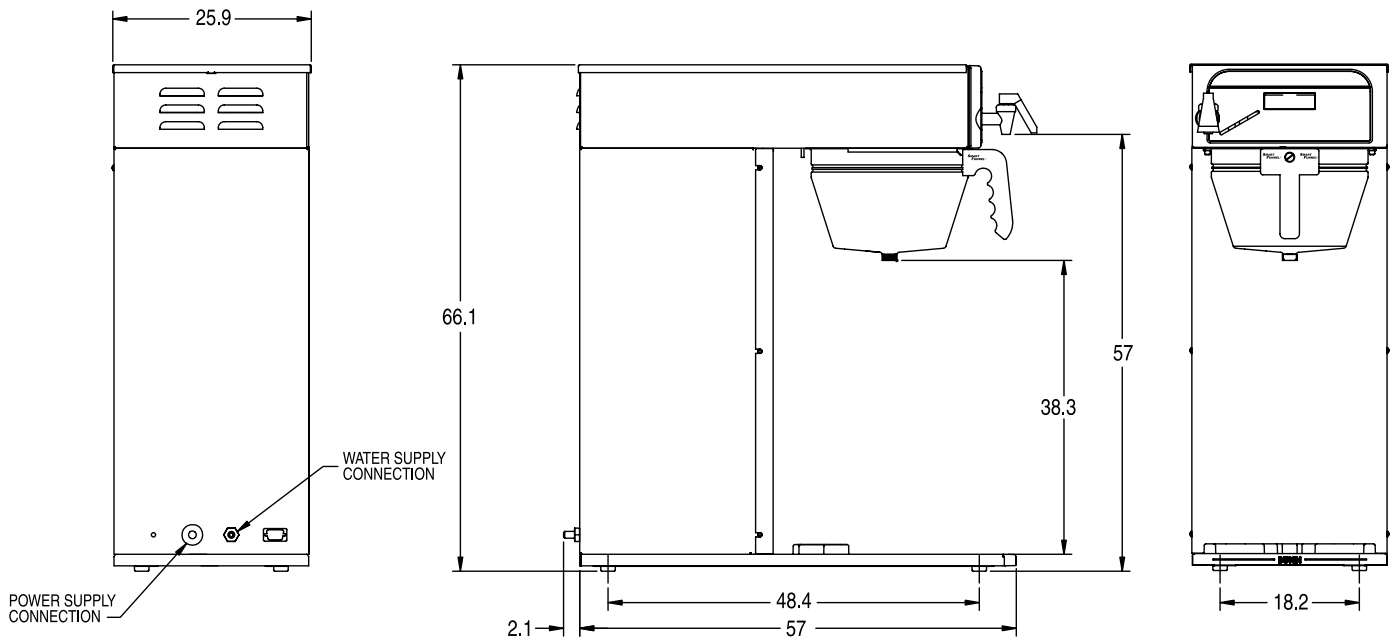

BUNN Corporation - 1400 Stevenson Drive Springfield, Illinois 62703 • USA • +1-217-529-6601 • Fax +1-217-529-2827 • www.bunn.com

BUNN® practices continuous product research and improvement. We reserve the right to change specifications and product design without notice. Such revisions do not entitle the buyer to corresponding changes, improvements, additions or replacements for previously purchased equipment.

All dimensions shown in centimeters. Bunn Corporation owns all copyrights relating to materials in this publication. Please contact Bunn Corporation to request permission to reproduce any portion of this publication.